

A5a Flying Probe Test System

Automated test for rigid PCBs



- ▲ 8 Test Heads
- ▲ Fully Automated
- ▲ Soft touch probe
- ▲ Kelvin 4-Wire Testing

COMBINEDSTRENGTH

atg
test systems

**LUTHER &
MAELZER**

Technical Specification

Flying Probe Test System A5a

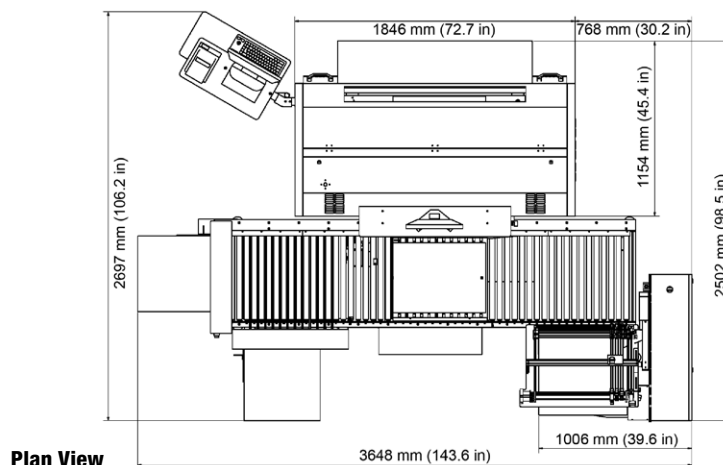

Mechanics

Fully automatic loading, test and stacker system for different board sizes in succession without stopping test procedure
Basic unit with 8 test probes (4 top, 4 bottom)

Board Handling

	Manual mode	Automatic mode
Max. Board Size (X x Y)	610 x 460 mm	610 x 460 mm
Min. Board Size (X x Y)	25 x 25 mm	100 x 100 mm
Test area (X x Y)	610 x 460 mm	610 x 460 mm
Board Thickness	up to 7 mm	up to 4 mm

Loader capacity	390 mm 240 boards / 1.6 mm thickness
Cycle time automation	20 s

Smallest pad	50 µm / 2.0 mil
Smallest pitch	100 µm / 4.0 mil
System accuracy	± 20 µm / ± 0.8 mil
Repeatable accuracy	± 10 µm / ± 0.4 mil
Soft touch probes	5 to 15 g / no witness marks
or	
Rigid Probes	10 to 100 g

Electronics

Continuity test	1 Ω to 10 k Ω
Isolation test	up to 25 M Ω (FM), up to 2 G Ω (ohmic) MicroShortDetection®
Test voltage	up to 250 V or up to 500 V

Camera System

4 cameras (640 x 480 pixel) for rapid optical scanning of top and bottom side
Resolution from 5 µm / pixel

Options

- 4-wire measurement: 1 m Ω to 1 k Ω (± 0.1 m Ω ± 2 %)
Blades, 5 to 15 g
Kelvin, 0.5 to 5 g
- LaTest® open detection with LaTest®-blade probes: 1 to 10 g
- Embedded components test:

Measurement	Tolerance
R 1 Ω to 50 M Ω	± (0.5 Ω ± 0.5 %) < 10 M Ω ± 2 % > 10 M Ω
C 0.1 pF to 100 µF	± (0.03 pF ± 2 %)
L 0.2 µH to 5000 µH	± (0.1 µH ± 2 %)
- Marking System – Label Printer or Inkjet Printer
- Retest of fault files from grid test systems with barcode support
- Label printer with barcode support
- Repair software
- Glass calibration board

Data Input Format IPC-D-356A

Network Connection Ethernet, TCP / IP

Power Supply 3 x 400 V, 50 Hz (3 x 208 V, 60 Hz), 2500 VA

Power Supply Vacuum Pump for Vacuum Table 3 x 400 V, 50 Hz (3 x 208 V, 60 Hz) 3000 VA

Compressed Air 6 bar / 90 psi, filtered, constant air quantity

Temperature 18 °C to 27 °C / 66 °F to 81 °F, ± 3 K
Relative Humidity 40 % to 60 %
Machine Weight 1850 kg

All information subject to change without notice!
May 2010



atg Luther & Maelzer GmbH

Zum Schlag 3 • D-97877 Wertheim • Germany
Phone +49-9342-291-0 • Fax +49-9342-395 10
sales@atg-lm.com • www.atg-lm.com

atg Luther & Maelzer GmbH

Hagenburger Strasse 54 • D-31515 Wunstorf • Germany
Phone +49-5031-174-0 • Fax +49-5031-174 109
sales@atg-lm.com • www.atg-lm.com

