

Unit 1 General Description of Machine

Chapter 1 Analysis of Expected Application and Operation Life of Machine

This machine is only applicable to guide hole punching process of FPC boards and black/brown negative films and positioning holes of punching machines.

This machine has an operation life of 5 to 7 years under normal conditions of use (based on 8 hours a day).

Chapter 2 Dimensions

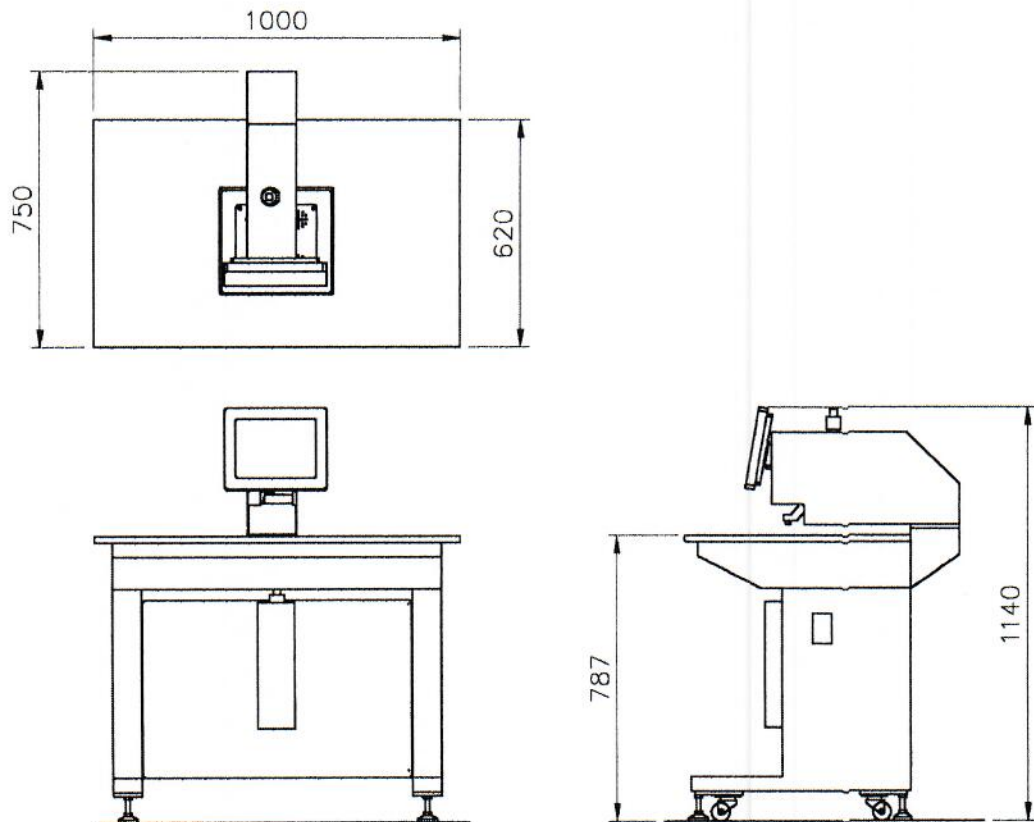

Unit: mm

Chapter 3 Illustration of Main Parts

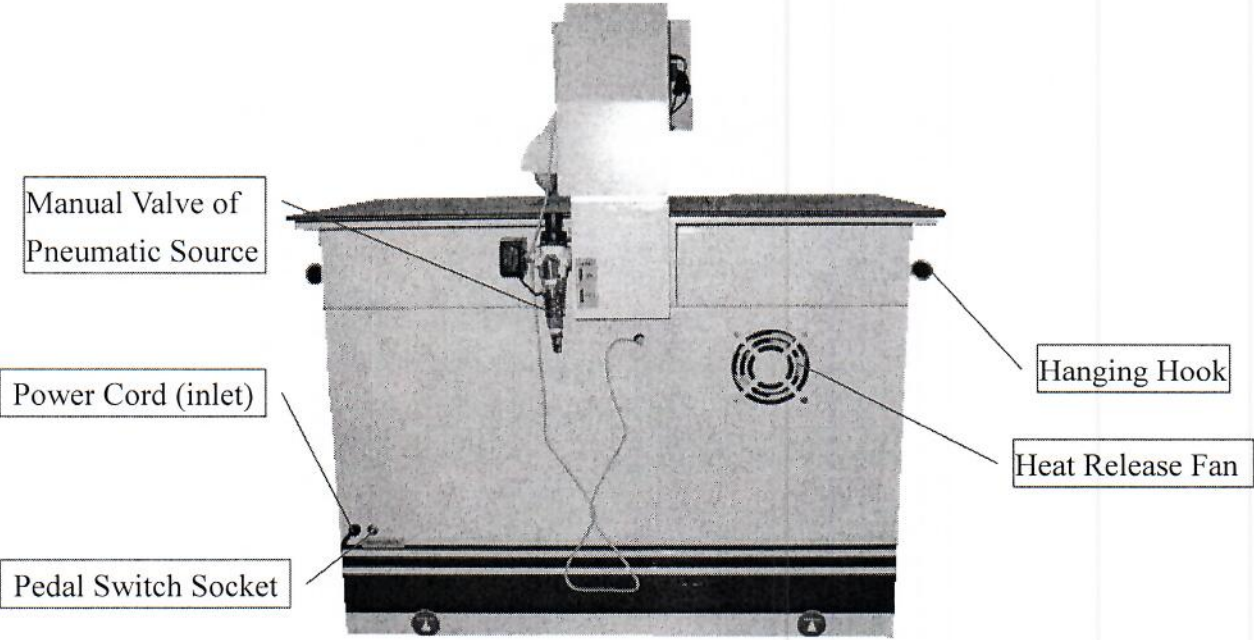
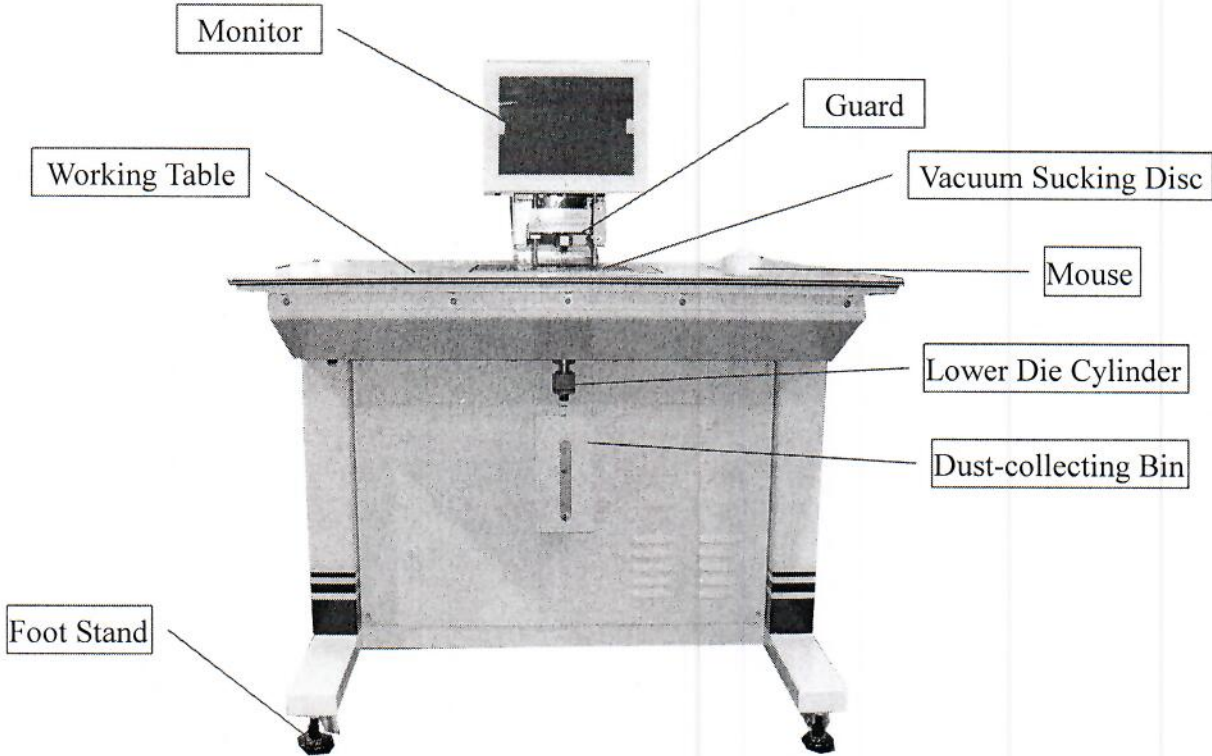

Upper die depth adjustment
(adjusted when workpiece
can't be punched)

Mouse

Power ON

IPC

Power OFF

